

Background colour : Black
 Indicator and gradinga colour : yellow
 Indication tolerance + 5°
 Resistance against 100 °C oil and 0.5 bar pressure

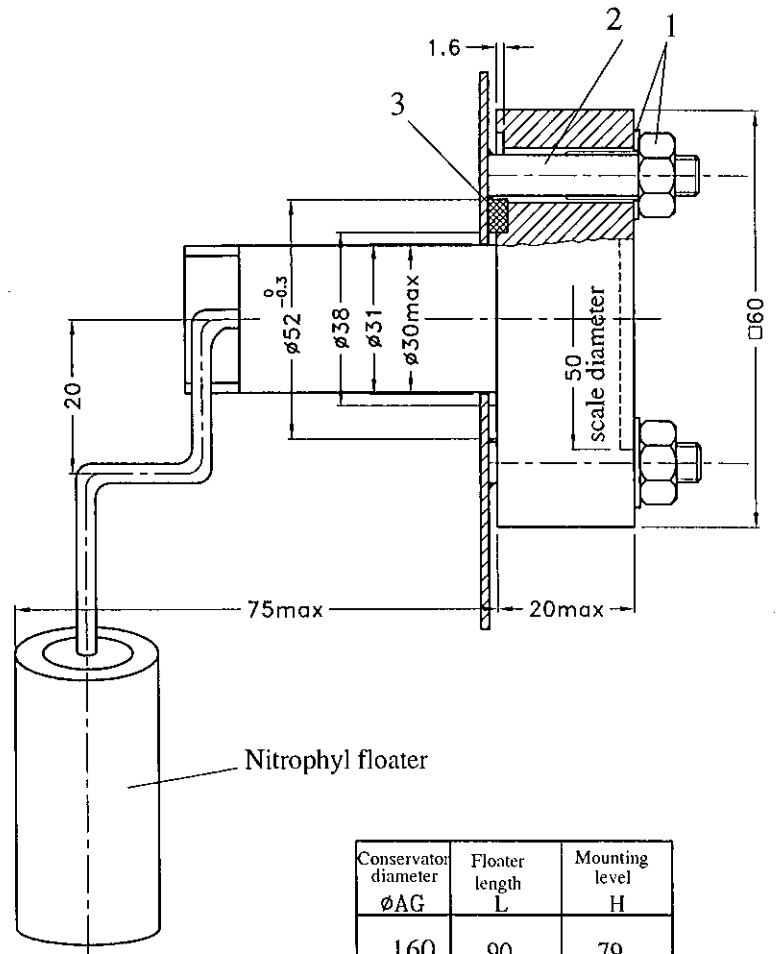

Conservator diameter øAG	Floater length L	Mounting level H
160	90	79
200	110	88
250	145	107
315	185	130
400	240	160
500	300	200

Mounting for conservator

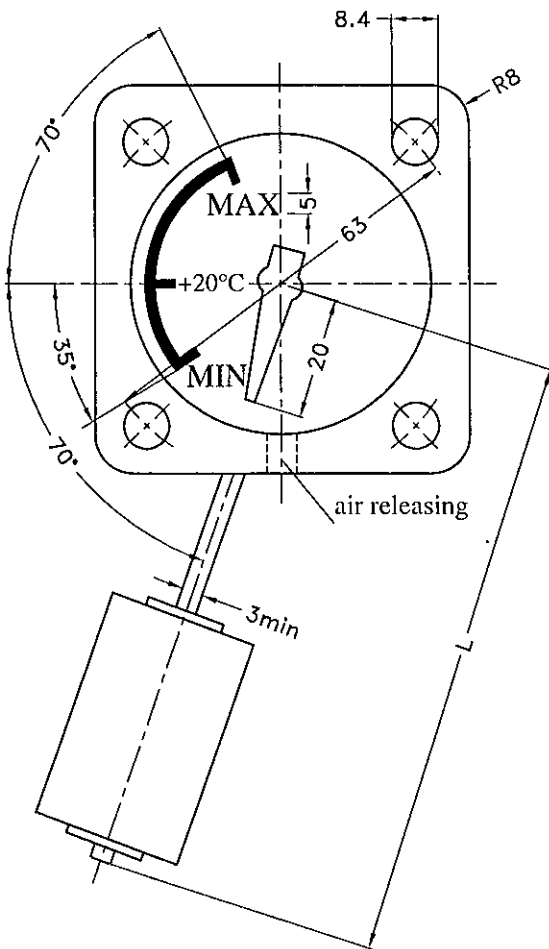
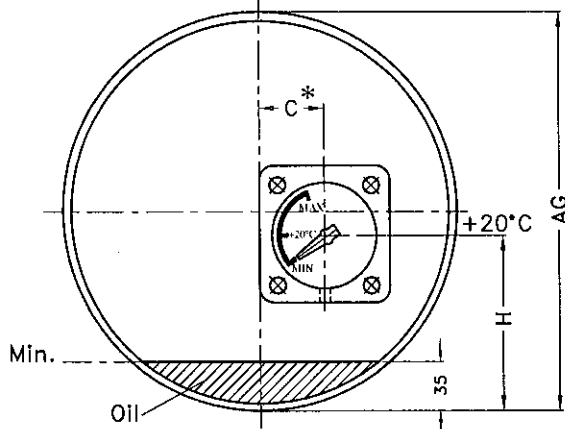

Designation for 315 mm AG the oil level indicator
 the characteristic specification is : ND 01 06 027 L=185

Weight : 0.15 kg

- 1) Hex. flange nut M6 according to DIN 6923
 material: carbon steel-class6 - A4G
 (With/Without serration)
- 2) Threaded bolt MP-M6x30-ND 0J 06 002
- 3) Flat sealing washer according to ND 0J 06 006

* C is refer to : ND 0C 02 017

Attachments:

Substitued of: ITN 200.058

Index	Mod.No.	Date	Modifications	Signature	Title:
					Magnetic oil level indicator with washer (without contact)
					Ordered by:
Tolerance:		Group:		Applied by:	Drawing Identification:
Scale: ---				F.Jozi	ITRI - - R111
				Check by:	Drawing No.:
				A.Karamzadeh	ND 01 06 -027 -
				Approved by:	Date:
				F.Joulaei	1398/01/20
				Page.Count No.:	Page No.:



شرکت ترانسفورماتور توزیع زنگان
 ZANGAN DISTRIBUTION TRANSFORMER CO.